

APPLICATION:

PRODUCT NAME:

ATMOSPHERIC VACUUM BREAKER

JOB NAME:

\_\_\_\_\_ SPECIAL CONFIGURATION  
(CHECK BASE MODEL AND OPTIONS)

QUANTITY: ITEM NO.

MODEL:  
 2932-8002

OPTIONS OR MODIFICATIONS

OTHER \_\_\_\_\_

FEATURES:

- \* 3/8" F INLET AND OUTLET
- \* 2.2 GPM MAX. AT 80 PSI
- \* POLISHED CHROME FINISH

SYSTEM LIMITS

- \* TEMP: 40°F MIN. TO 140°F MAX.
- \* PRESSURE 100 PSI MAX. STATIC

SHIPPING WEIGHT

- \* 0.5 LBS

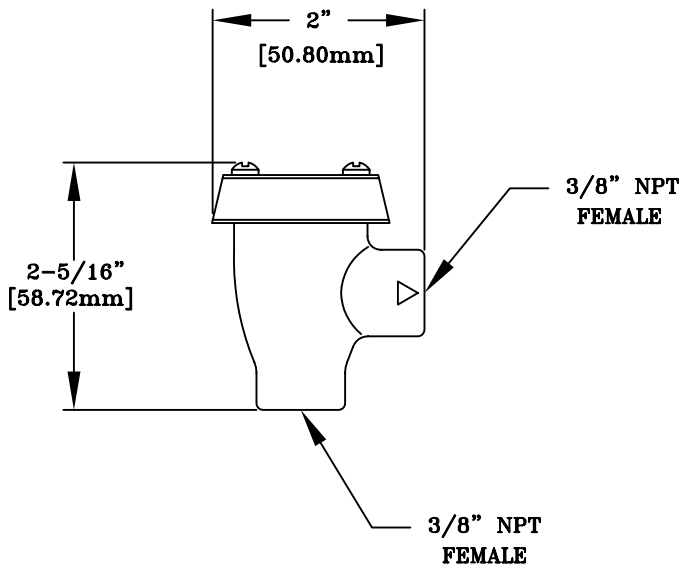

# FISHER

FISHER MANUFACTURING COMPANY  
TOLL FREE: 800-421-6162 - FAX: 800-832-8238  
information@fisher-mfa.com - www.fisher-mfa.com